

TECHNICAL BROCHURE



DUAL FUNCTION HEAT PUMPS 20kW – 100kW

MANUFACTURED BY:



CONTACT DETAILS:

+27 18 297 0326 / 7 (Tel)
+27 18 297 0318 (Fax)
www.mtechindustrial.com

PHYSICAL ADDRESS:

24 Totius street
Totius park Block E
Potchefstroom
2531

POSTAL ADDRESS:

PO Box 19855
Noordbrug
2522

ENERFLOW ED-MT DUAL FUNCTION HEAT PUMPS: ENERGY EFFICIENT WATER HEATER/WATER CHILLER UNITS

The **ENERFLOW ED-MT** series dual function heat pumps are extremely energy efficient and versatile. They can either:

- Produce hot and cold water simultaneously.
- Produce hot water with cold air as a by-product.
- Produce chilled water with hot air as a by-product.

ENERFLOW ED-MT dual function heat pumps extract heat either from the ambient air or from a water reservoir to be chilled and transfer it either to a water reservoir to be heated or to the ambient air.

ENERFLOW ED-MT dual function heat pumps consume (in the form of electrical power) only a fraction of the energy transferred to the heat sink (ambient air or hot water).

ENERFLOW ED-MT dual function heat pumps can produce 7 units of "Hot" and "cold" (depending on the temperatures of the source and sink) by using only 1 unit of electrical power.

ADVANTAGES

- High energy cost reductions.
- Reduction in the cost of electrical installation.
- Space saving.

APPLICATION

ENERFLOW ED-MT dual function heat pumps are ideally suited for the following application:

- Hotels, hospitals, office blocks, universities, residential units
- Food processing industry
- Industrial hot and cold water systems
- Bakeries
- Dairies.

EASY INSTALLATION

Installation is a simple matter of water pipe connections and power supply. The **ENERFLOW ED-MT** models are designed for outdoor as well as

indoor applications. The only requirement is access to external air.

NO MAINTENANCE

ENERFLOW ED-MT dual function heat pumps do not require maintenance as is the case with coal and diesel fired boilers. The units are sealed and designed for trouble free operation. It is equipped with automatic fault finding light indicators and in the unlikely event of a malfunction the problem will show clearly, enabling even an unskilled person to rectify the problem.

HIGH INLET WATER TEMPERATURE

A unique patented heat exchanger enables **ENERFLOW ED-MT** dual function heat pumps to heat water up to a temperature of 60 °C even when the inlet water temperature is as high as 55 °C. The fact that **ENERFLOW ED-MT** heat pumps can handle high water inlet temperatures is very advantageous as it enables water in a storage tank to be heated until the temperature at the bottom of the tank is only 5 °C lower than the maximum temperature at the top of the tank. In so doing the energy storage capacity of the tank is maximized.

HARD WATER

In areas where hard water scale (i.e. calcium) build-up and insulate the inside of heat exchangers and produce such loss of efficiency, **M-Tech Industrial** can install a water softener system. The system, once installed on the hot water heat exchanger, operates silently, automatically and permanently never needing power, salt or chemicals. The system will dissolve any scale and will also neutralize any acid water.

QUIET OPERATION

Advanced fans, with airfoil blades and a very noise level, are used on **ENERFLOW** heat pumps. The fan motors are also protected against moisture and dust.

REVERSE CYCLE DEFROST

Reverse cycle defrost, provided on the **ENERFLOW ED-MT** models, is the most efficient method for defrosting the air heat

exchanger. Defrost is accomplished in a very short time period and any liquid refrigerant formed in the air heat exchanger is evaporated in the water heat exchanger before entering the compressor.

This eliminates the possibility of any liquid refrigerant, which can damage the compressor, from entering the compressor.

FREE COLD AIR

The by-product of **ENERFLOW ED-MT** heat pumps is cold air which can be ducted to any area of choice and used for air conditioning purposes.

PRINCIPLES OF OPERATION

ENERFLOW ED-MT dual function heat pumps are based on the well known vapour compression cycle described and illustrated below:

- The refrigerant enters the compressor as vapour at low pressure and temperature.
- It enters the condenser (either the hot water heat exchanger or the air coil) as vapour at high pressure and temperature.
- The refrigerant is condensed due to the heat that is transferred to the water or the air.
- The pressure of the liquid decreases through the expansion valve causing the temperature to drop sharply.
- The liquid at low pressure vaporized in the evaporator (either the air coil or the chilled water heat exchanger) as a result of heat transfer.
- The cycle is completed as vapour re-enters the compressor.

WARRANTY

M-Tech Industrial warrants this equipment to be free from defects in material and workmanship for a period of 12 months from date of shipment provided the correct installation and water treatment procedures were followed. Any units or parts proving defective within this period will be repaired or replaced at our option when returned to our factory transportation charges pre-paid. M-Tech Industrial will not be responsible for any installation or removal costs.

AUTOMATIC OPERATION

ENERFLOW ED-MT dual function heat pumps are completely automatic. Thermostats are used to determine if (1) only hot or (2) only chilled or (3)

both hot and chilled water are needed. The units will automatically switch to the appropriate function.

MODES OF OPERATION

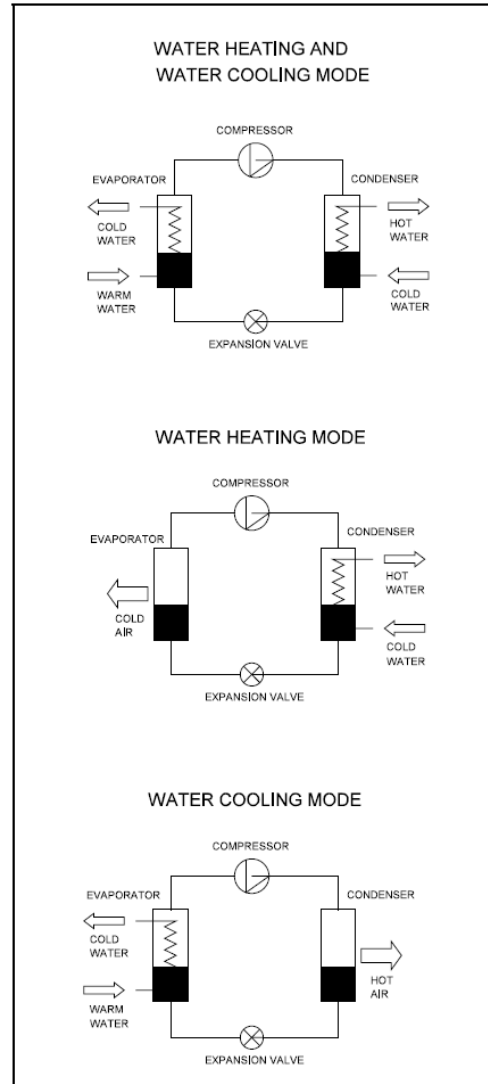

TECHNOLOGY

ENERFLOW ED-MT heat pumps are the end product of a fine engineering effort piloted by M-Tech Industrial in collaboration with other engineering research institutes. Computer aided design verified by experimental testing supported the projects throughout its development and manufacturing phases.

OPERATING LIMITS

WATER HEATING MODE

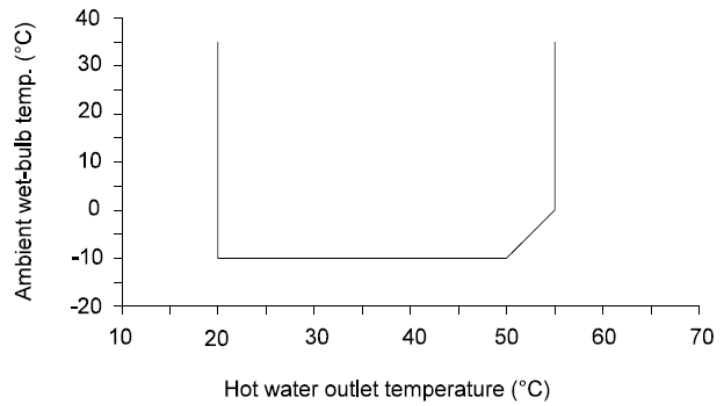

WATER COOLING MODE

Ambient temperature : 42 °C maximum
Cold water outlet temperature : 6 °C minimum

WATER HEATING AND COOLING MODE

Hot water outlet temperature : 60 °C maximum
Cold water outlet temperature : 6 °C minimum

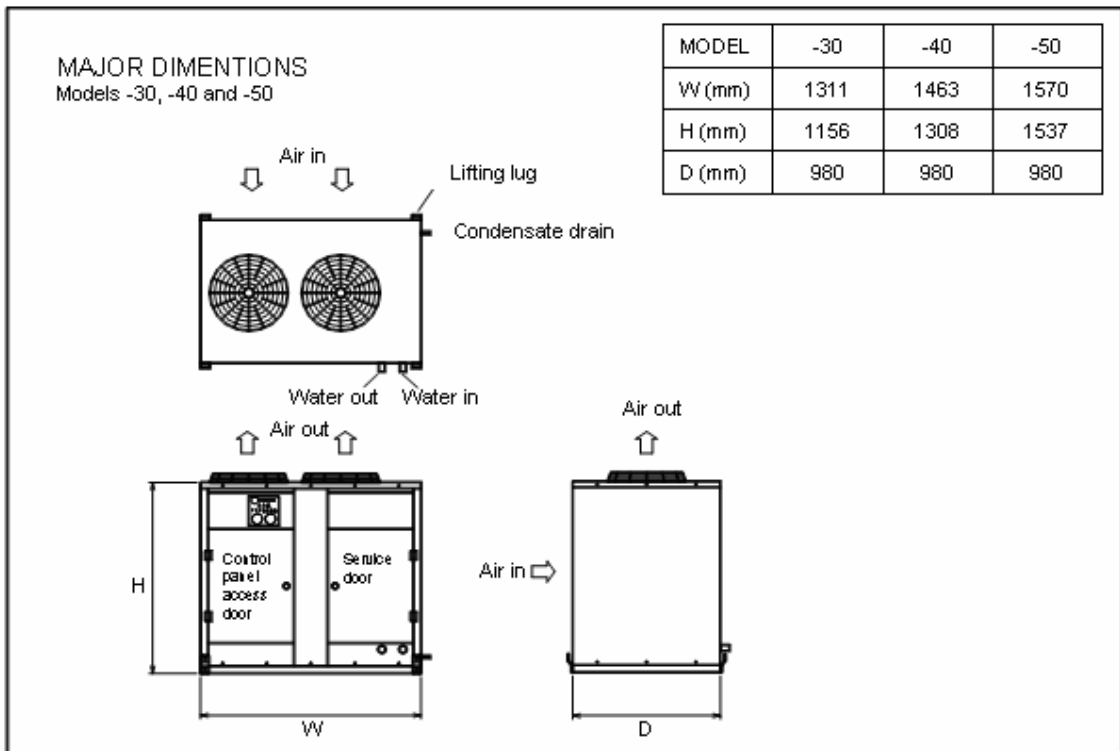
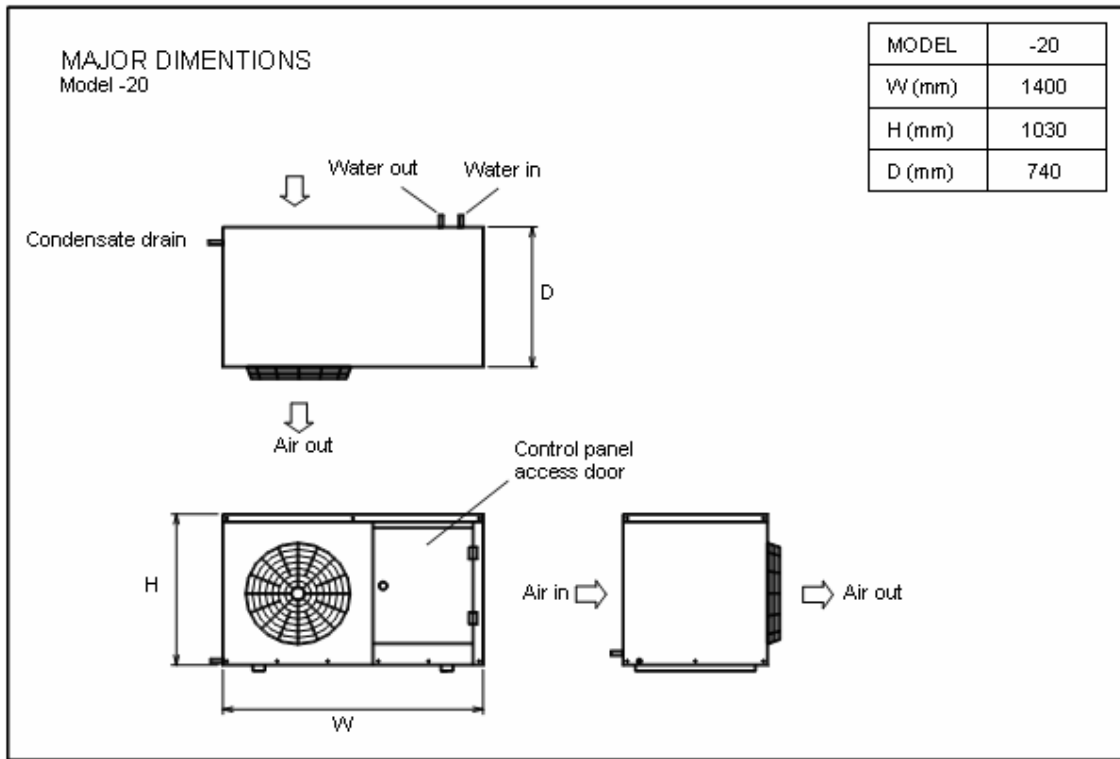

MAJOR DIMENTIONS
Models -60, -80 and -100

MODEL	-60	-80	-100
W (mm)	2622	2926	3140
H (mm)	1156	1308	1537
D (mm)	980	980	980

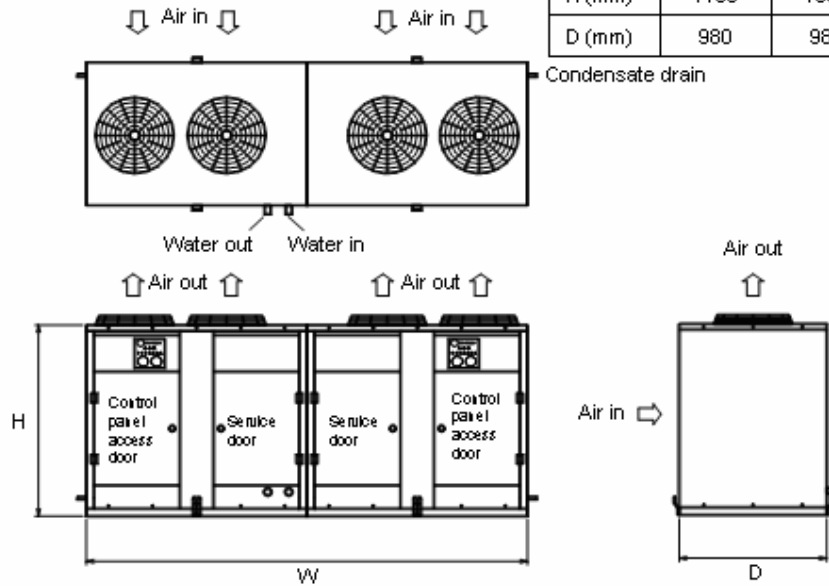

SPECIFICATIONS: ENERFLOW ED-MT DUAL FUNCTION HEAT PUMPS

MODEL		ED20MT	ED30MT	ED40MT	ED50MT	ED60MT	ED80MT	ED100MT	
HEATING CAPACITY		(Water 55°C out, air 15°C WB)							
Heat output	kW	18.3	27.9	36.9	46.4	55.9	73.8	92.9	
Water flow	l/min	52.2	79.8	105.9	133.2	160.5	211.9	266.7	
Heating COP		3.3	3.3	3.4	3.3	3.3	3.4	3.3	
COOLING CAPACITY		(15°C in, 10°C out, air 30°C DB)							
Cooling capacity	kW	14.0	21.3	28.2	35.5	42.6	56.5	71.0	
Water flow	l/min	40.2	61.1	81.0	101.9	122.3	162.2	203.8	
Cooling COP		2.9	2.8	2.9	2.8	2.9	2.8		
ELECTRICAL									
Phases		3.0	3.0	3.0	3.0	3.0	3.0	3.0	
Voltage	Volt	3.0	3.0	3.0	3.0	3.0	3.0	3.0	
Power (Max cont.)	kW	6.4	9.9	12.5	16.4	19.8	25.0	32.8	
Current (Max cont.)	Amps	10.9	20.0	24.2	35.0	40.0	48.4	70.0	
CAPACITY STEPS		100 – 0	100 – 0	100 – 0	100 – 0	100 – 50 – 0	100 – 50 – 0	100 – 50 – 0	
CASING		Stainless Steel							
Dimension HxWxD		1030x1400 x 740	1156x1311 x 980	1308x1463 x 980	1537x1570 x 980	1156x2622 x 980	1308x2926 x 980	1537x3140 x 980	
COMPRESSOR		Hermetically sealed reciprocating							
No. of cylinders		4	4	4	4	4x2	4x2	4x2	
Displacement 50 Hz	m ³ /h	17.7	30.9	38.6	46.3	30.9 x 2	38.6 x 2	46.3 x 2	
Speed	rpm	2900.0	2900.0	2900.0	2900.0	2900.0	2900.0	2900.0	
Oil charge	Fl oz	70.0	128.0	128.0	128.0	128 x 2	128 x 2	128 x 2	
Oil type		Caltex Capella WF32							
HEAT EXCHANGER (WATER)		Fluted tube							
HEAT EXCHANGER (AIR)									
(Rows x Columns) x No.		4 x 36 x 1	4 x 39 x 1	4 x 45 x 1	4 x 54 x 1	4 x 39 x 2	4 x 45 x 2	4 x 54 x 2	
Number of circuits		8.0	13.0	15.0	18.0	13 x 2	15 x 2	18 x 2	
Fin patch	mm	2.5	2.5	2.5	2.5	2.5	2.5	2.5	
Face area	m ²	0.7	1.0	1.3	1.7	0.98 x 2	1.31 x 2	1.72 x 2	
FAN		Axial flow							
Fan speed	rpm	1350.0	1100.0	1350.0	1350.0	1100.0	1350.0	1350.0	
Fan diameter	mm	500 x 1	500 x 2	500 x 2	500 x 2	500 x 4	500 x 4	500 x 4	
Air flow	m ³ /min	122.0	156.0	241.0	267.0	312.0	482.0	534.0	
Face velocity	m/s	3.1	2.7	3.1	2.6	2.7	3.1	2.6	
Power input	kW	0.7	0.5 x 2	0.7 x 2	0.7 x 2	0.5 x 4	0.7 x 4	0.7 x 4	
Noise level	dB 3m	83.0	79.0	83.0	83.0	79.0	83.0	83.0	
REFRIGERANT		R22							
Control		Thermostatic expansion valve							
No. of circuits		1.0	1.0	1.0	1.0	2.0	2.0	2.0	
Charge	kg	6.0	7.0	8.0	9.0	7 x 2	8 x 2	9 x 2	
DEFROSTING METHOD		Reverse cycle (Optional)							
PIPE CONNECTION									
Water inlet/outlet	mm	25.4	31.8	38.1	38.1	38.1	50.8	50.8	
Drain	mm	19.1	19.1	19.1	19.1	19.1	19.1	19.1	
MACHINE WEIGHT		kg	300.0	350.0	400.0	450.0	700.0	800.0	900.0

HEATING CAPACITY: WATER HEATING MODE

Q = Heat output (kW)

P = Power input, including fan, excluding pump (kW)

COP = Coefficient of performance (Q/P)

T_{wat} = Hot water outlet temperature (°C)

T_{wb} = Ambient air wet-bulb temperature (°C)

Hot water outlet temperature is 5°C higher than inlet temperature

UNIT	T _{wat} →	40.0			45.0			50.0			55.0			60.0		
	T _{wb}	Q	P	COP	Q	P	COP	Q	P	COP	Q	P	COP	Q	P	COP
ED20MT	-5.0	9.8	3.5	2.8	9.2	3.5	2.6	8.5	3.5	2.4	7.8	3.5	2.2	7.2	3.5	2.1
	0.0	12.1	3.8	3.2	11.6	3.9	2.9	11.0	4.0	2.7	10.3	4.1	2.5	9.6	4.1	2.3
	5.0	14.6	4.2	3.5	14.0	4.3	3.2	13.4	4.5	3.0	12.8	4.6	2.8	12.1	4.7	2.6
	10.0	17.3	4.5	3.9	16.7	4.7	3.6	16.1	4.9	3.3	15.4	5.0	3.1	14.7	5.2	2.8
	15.0	20.3	4.8	4.2	19.7	5.0	3.9	19.0	5.3	3.6	18.3	5.5	3.3	17.5	5.7	3.1
	20.0	23.7	5.1	4.6	23.0	5.4	4.3	22.2	5.7	3.9	21.5	5.9	3.6	20.6	6.2	3.3
ED30MT	-5.0	14.7	5.2	2.8	13.7	5.3	2.6	12.7	5.3	2.4	11.6	5.2	2.2	10.6	5.2	2.1
	0.0	18.4	5.8	3.2	17.5	5.9	2.9	16.5	6.1	2.7	15.4	6.1	2.5	14.2	6.1	2.3
	5.0	22.3	6.4	3.5	21.4	6.6	3.3	20.3	6.7	3.0	19.2	6.9	2.8	18.1	7.0	2.6
	10.0	26.8	6.9	3.9	25.7	7.2	3.6	24.6	7.4	3.3	23.4	7.7	3.1	22.1	7.9	2.8
	15.0	31.7	7.5	4.2	30.5	7.8	3.9	29.2	8.1	3.6	27.9	8.4	3.3	26.6	8.7	3.0
	20.0	37.3	8.1	4.6	36.0	8.4	4.3	34.5	8.8	3.9	33.0	9.2	3.6	31.5	9.6	3.3
ED40MT	-5.0	20.2	6.9	2.9	19.1	7.0	2.7	17.9	7.1	2.5	16.7	7.1	2.3	15.5	7.1	2.2
	0.0	24.8	7.6	3.2	23.7	7.9	3.0	22.6	8.0	2.8	21.4	8.2	2.6	20.1	8.2	2.4
	5.0	29.5	8.3	3.6	28.5	8.6	3.3	27.3	8.8	3.1	26.1	9.1	2.9	24.8	9.2	2.7
	10.0	35.0	8.9	3.9	33.8	9.3	3.6	32.6	9.6	3.4	31.3	9.9	3.2	29.9	10.2	2.9
	15.0	41.0	9.6	4.3	39.7	10.0	4.0	38.4	10.4	3.7	36.9	10.8	3.4	35.4	11.2	3.2
	20.0	47.9	10.3	4.7	46.4	10.8	4.3	44.8	11.2	4.0	43.2	11.7	3.7	41.5	12.1	3.4
ED50MT	-5.0	25.6	9.0	2.8	24.3	9.2	2.6	22.9	9.3	2.5	21.4	9.3	2.3	20.0	9.3	2.2
	0.0	31.3	10.0	3.1	30.1	10.3	2.9	28.7	10.5	2.7	27.3	10.7	2.6	25.6	10.8	2.4
	5.0	37.3	10.9	3.4	36.0	11.2	3.2	34.6	11.6	3.0	33.1	11.8	2.8	31.5	12.1	2.6
	10.0	44.1	11.7	3.8	42.6	12.2	3.5	41.1	12.6	3.3	39.5	13.0	3.0	37.7	13.4	2.8
	15.0	51.6	12.6	4.1	50.0	13.2	3.8	48.3	13.7	3.5	46.4	14.2	3.3	44.5	14.6	3.0
	20.0	60.3	13.7	4.4	58.4	14.2	4.1	56.4	14.8	3.8	54.4	15.4	3.5	52.1	15.9	3.3
ED60MT	-5.0	29.3	10.4	2.8	27.4	10.5	2.6	25.3	10.5	2.4	23.1	10.4	2.2	21.2	10.3	2.1
	0.0	36.9	11.6	3.2	35.0	11.9	2.9	33.0	12.1	2.7	30.8	12.2	2.5	28.5	12.3	2.3
	5.0	44.7	12.7	3.5	42.7	13.1	3.3	40.6	13.5	3.0	38.5	13.8	2.8	36.1	14.1	2.6
	10.0	53.5	13.8	3.9	51.4	14.4	3.6	49.1	14.9	3.3	46.8	15.3	3.1	44.3	15.8	2.8
	15.0	63.4	15.0	4.2	61.0	15.6	3.9	58.5	16.2	3.6	55.9	16.9	3.3	53.1	17.4	3.0
	20.0	74.7	16.1	4.6	71.9	16.9	4.3	69.0	17.6	3.9	66.0	18.4	3.6	62.9	19.1	3.3
ED80MT	-5.0	40.3	13.8	2.9	38.2	14.1	2.7	35.8	14.2	2.5	33.3	14.2	2.3	31.1	14.2	2.2
	0.0	49.5	15.3	3.2	47.5	15.7	3.0	45.2	16.1	2.8	42.8	16.3	2.6	40.1	16.4	2.4
	5.0	59.1	16.6	3.6	57.0	17.1	3.3	54.7	17.7	3.1	52.2	18.1	2.9	49.6	18.5	2.7
	10.0	69.9	17.9	3.9	67.6	18.6	3.6	65.1	19.3	3.4	62.6	19.9	3.2	59.8	20.4	2.9
	15.0	82.0	19.2	4.3	79.4	20.0	4.0	76.7	20.8	3.7	73.8	21.6	3.4	70.8	22.4	3.2
	20.0	95.8	20.6	4.7	92.7	21.5	4.3	89.6	22.4	4.0	86.4	23.4	3.7	83.0	24.3	3.4
ED100MT	-5.0	51.1	18.0	2.8	48.6	18.4	2.6	45.7	18.6	2.5	42.8	18.6	2.3	40.1	18.6	2.2
	0.0	62.6	19.9	3.1	60.2	20.5	2.9	57.5	21.0	2.7	54.5	21.3	2.6	51.2	21.5	2.4
	5.0	74.6	21.7	3.4	71.9	22.4	3.2	69.2	23.1	3.0	66.2	23.7	2.8	62.9	24.2	2.6
	10.0	88.1	23.5	3.8	85.2	24.4	3.5	82.2	25.3	3.3	78.9	26.0	3.0	75.5	26.7	2.8
	15.0	103.3	25.3	4.1	100.0	26.3	3.8	96.6	27.4	3.5	92.9	28.3	3.3	89.0	29.2	3.0
	20.0	120.6	27.3	4.4	116.8	28.5	4.1	112.7	29.6	3.8	108.7	30.8	3.5	104.3	31.9	3.3

ED-MT Series: Water heating mode

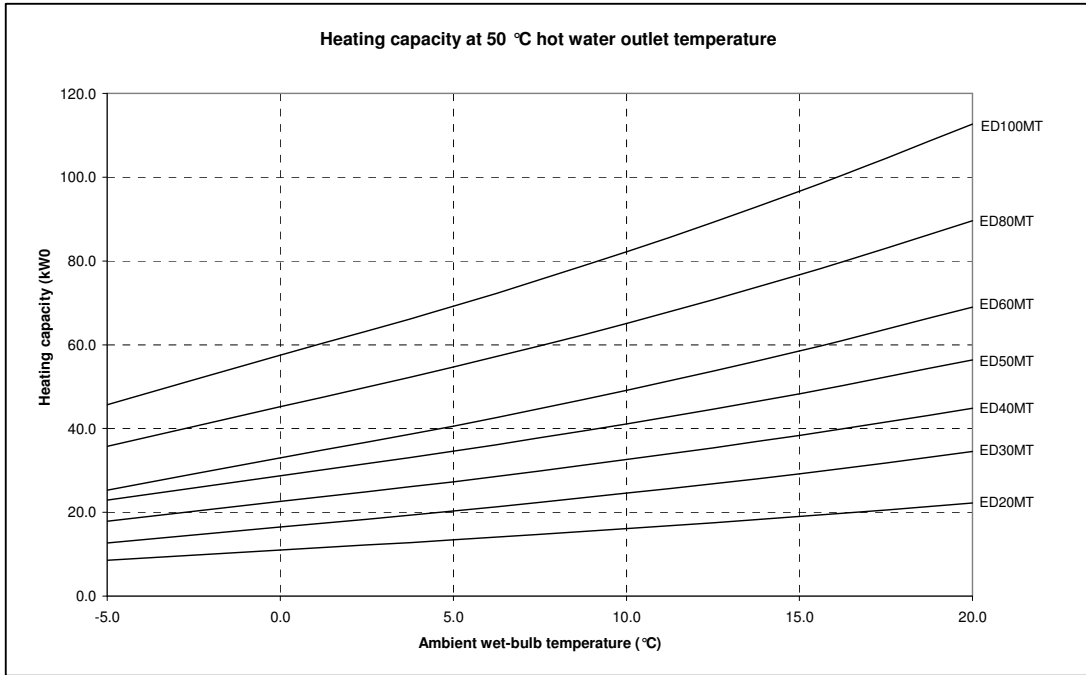

ED-MT Series: Water heating mode

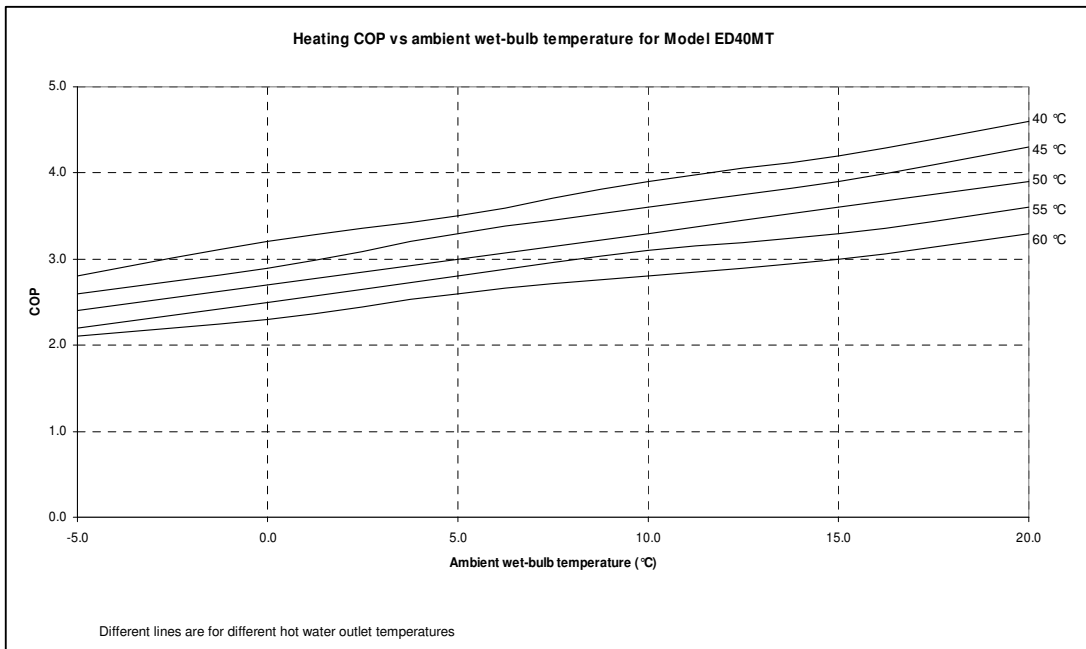

COOLING CAPACITY: WATER COOLING MODE

Q = Cooling capacity (kW)

P = Power input, including fan, excluding pump (kW)

COP = Coefficient of performance (Q/P)

Twat = Chilled water outlet temperature (°C)

Tamb = Ambient air dry-bulb temperature (°C)

Chilled water outlet temperature is 5°C lower than inlet temperature

UNIT	Tamb→	20.0				25.0				30.0				35.0				40.0			
	Twat	Q	P	COP	Q	P	COP	Q	P	COP	Q	P	COP	Q	P	COP	Q	P	COP		
ED20MT	-5.0	9.0	3.4	2.6	8.4	3.5	2.4	7.7	3.6	2.1	7.1	3.7	1.9	6.5	3.7	1.7					
	0.0	11.0	3.7	3.0	10.3	3.9	2.7	9.6	4.0	2.4	8.9	4.1	2.2	8.2	4.2	1.9					
	5.0	13.2	4.0	3.3	12.4	4.2	3.0	11.7	4.4	2.7	10.9	4.5	2.4	10.1	4.7	2.2					
	10.0	15.7	4.4	3.6	14.8	4.6	3.2	14.0	4.8	2.9	13.1	5.0	2.6	12.2	5.1	2.4					
	15.0	18.4	4.7	3.9	17.4	5.0	3.5	16.4	5.2	3.2	15.4	5.4	2.9	14.4	5.6	2.6					
	20.0	21.3	5.1	4.2	20.2	5.4	3.8	19.1	5.6	3.4	18.0	5.9	3.1	16.9	6.1	2.7					
ED30MT	-5.0	13.6	5.2	2.6	12.6	5.4	2.3	11.6	5.5	2.1	10.5	5.6	1.9	9.5	5.6	1.7					
	0.0	16.8	5.8	2.9	15.6	6.0	2.6	14.5	6.2	2.4	13.3	6.3	2.1	12.2	6.4	1.9					
	5.0	20.4	6.4	3.2	19.1	6.6	2.9	17.7	6.8	2.6	16.4	7.0	2.3	15.1	7.2	2.1					
	10.0	24.4	7.0	3.5	22.9	7.3	3.1	21.3	7.5	2.8	19.9	7.7	2.6	18.3	8.0	2.3					
	15.0	28.5	7.7	3.7	26.9	8.0	3.4	25.2	8.3	3.0	23.4	8.5	2.7	21.8	8.8	2.5					
	20.0	33.1	8.4	4.0	31.2	8.7	3.6	29.3	9.1	3.2	27.3	9.4	2.9	25.4	9.7	2.6					
ED40MT	-5.0	18.4	6.8	2.7	17.2	7.1	2.4	16.0	7.3	2.2	14.7	7.4	2.0	13.5	7.5	1.8					
	0.0	22.3	7.5	3.0	21.0	7.8	2.7	19.6	8.0	2.4	18.3	8.2	2.2	16.9	8.4	2.0					
	5.0	26.8	8.2	3.3	25.2	8.5	3.0	23.7	8.8	2.7	22.2	9.1	2.5	20.7	9.3	2.2					
	10.0	31.7	8.9	3.6	30.0	9.3	3.2	28.2	9.6	2.9	26.5	9.9	2.7	24.8	10.2	2.4					
	15.0	37.0	9.7	3.8	35.1	10.1	3.5	33.1	10.5	3.2	31.2	10.8	2.9	29.2	11.2	2.6					
	20.0	42.6	10.5	4.1	40.5	11.0	3.7	38.3	11.4	3.4	36.1	11.8	3.0	33.9	12.3	2.8					
ED50MT	-5.0	23.0	8.8	2.6	21.6	9.2	2.4	20.1	9.4	2.1	18.6	9.6	1.9	17.1	9.8	1.7					
	0.0	28.0	9.7	2.9	26.3	10.1	2.6	24.7	10.4	2.4	23.0	10.7	2.2	21.3	10.9	1.9					
	5.0	33.6	10.6	3.2	31.7	11.1	2.9	29.8	11.5	2.6	27.9	11.8	2.4	26.0	12.2	2.1					
	10.0	39.8	11.6	3.4	37.7	12.1	3.1	35.5	12.5	2.8	33.3	12.9	2.6	31.1	13.3	2.3					
	15.0	46.4	12.6	3.7	44.0	13.2	3.3	41.5	13.6	3.0	39.1	14.1	2.8	36.6	14.6	2.5					
	20.0	53.6	13.8	3.9	50.9	14.4	3.5	48.1	14.9	3.2	45.3	15.5	2.9	42.4	16.0	2.7					
ED60MT	-5.0	27.2	10.5	2.6	25.2	10.8	2.3	23.2	11.0	2.1	21.1	11.2	1.9	18.9	11.2	1.7					
	0.0	33.6	11.6	2.9	31.3	12.0	2.6	29.0	12.3	2.4	26.7	12.6	2.1	24.4	12.8	1.9					
	5.0	40.8	12.7	3.2	38.2	13.2	2.9	35.5	13.6	2.6	32.9	14.0	2.3	30.2	14.3	2.1					
	10.0	48.8	14.0	3.5	45.7	14.5	3.1	42.6	15.0	2.8	39.7	15.5	2.6	36.7	15.9	2.3					
	15.0	57.1	15.3	3.7	53.8	15.9	3.4	50.3	16.5	3.0	46.9	17.1	2.7	43.5	17.6	2.5					
	20.0	66.2	16.8	4.0	62.4	17.5	3.6	58.6	18.1	3.2	54.7	18.8	2.9	50.8	19.5	2.6					
ED80MT	-5.0	36.7	13.6	2.7	34.3	14.1	2.4	31.9	14.5	2.2	29.5	14.8	2.0	26.9	15.0	1.8					
	0.0	44.6	15.0	3.0	41.9	15.5	2.7	39.3	16.0	2.4	36.6	16.5	2.2	33.8	16.8	2.0					
	5.0	53.5	16.4	3.3	50.5	17.0	3.0	47.5	17.6	2.7	44.5	18.1	2.5	41.4	18.6	2.2					
	10.0	63.4	17.8	3.6	59.9	18.5	3.2	56.5	19.2	2.9	53.0	19.9	2.7	49.6	20.4	2.4					
	15.0	74.0	19.4	3.8	70.1	20.2	3.5	66.3	20.9	3.2	62.4	21.7	2.9	58.4	22.4	2.6					
	20.0	85.3	21.1	4.1	81.0	21.9	3.7	76.6	22.8	3.4	72.2	23.7	3.0	67.8	24.5	2.8					
ED100MT	-5.0	45.9	17.7	2.6	43.1	18.3	2.4	40.2	18.9	2.1	37.2	19.3	1.9	34.2	19.6	1.7					
	0.0	55.9	19.4	2.9	52.7	20.2	2.6	49.4	20.9	2.4	46.1	21.4	2.2	42.7	21.9	1.9					
	5.0	67.2	21.3	3.2	63.5	22.1	2.9	59.6	22.9	2.6	55.7	23.6	2.4	51.9	24.3	2.1					
	10.0	79.5	23.2	3.4	75.3	24.1	3.1	71.0	25.0	2.8	66.6	25.9	2.6	62.2	26.6	2.3					
	15.0	92.8	25.3	3.7	88.0	26.3	3.3	83.0	27.3	3.0	78.1	28.3	2.8	73.1	29.2	2.5					
	20.0	107.3	27.5	3.9	101.8	28.7	3.5	96.2	29.8	3.2	90.6	30.9	2.9	84.9	32.0	2.7					

ED-MT Series: Water cooling mode

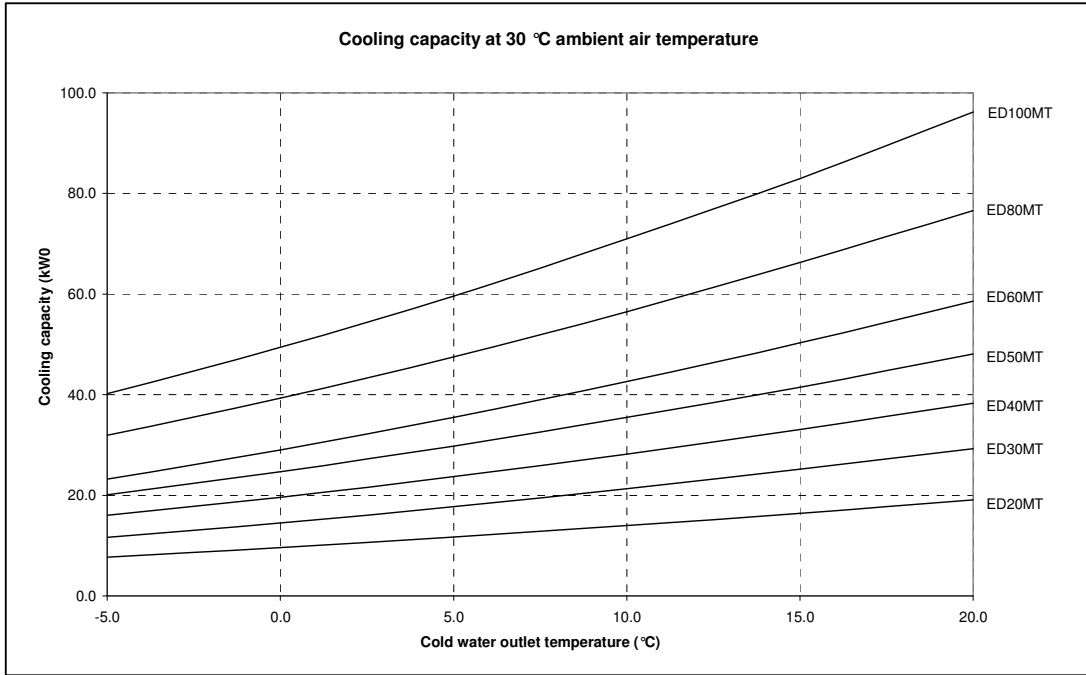

ED-MT Series: Water cooling mode

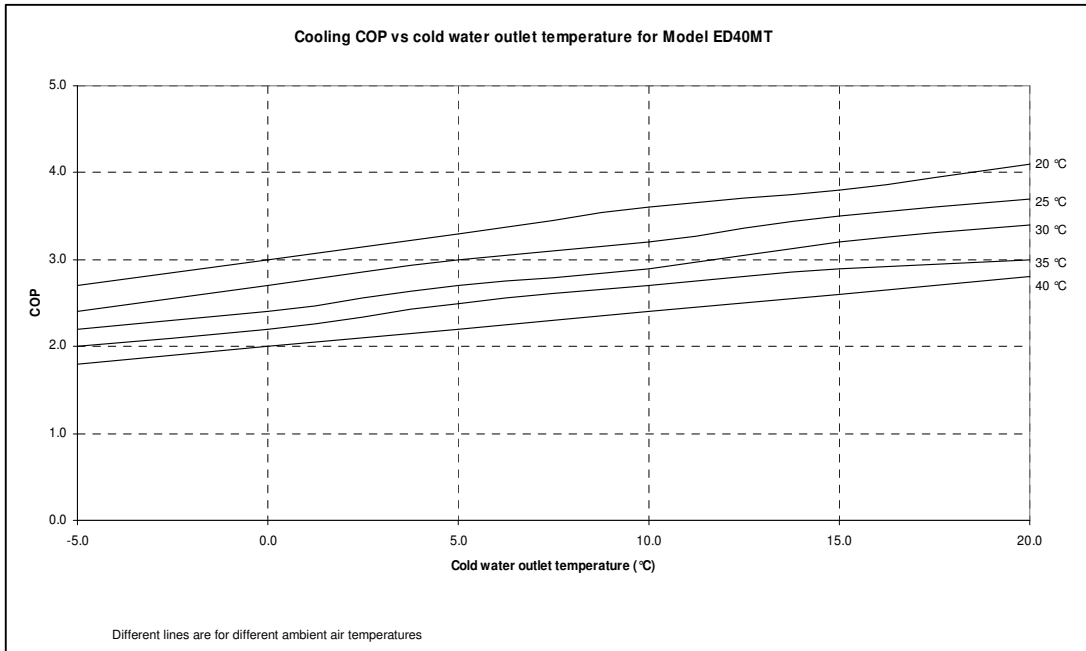

HEATING CAPACITY: WATER HEATING AND WATER COOLING MODE

Q = Heat output (kW)

P = Power input, including fan, excluding pump (kW)

COP = Coefficient of performance (Q/P)

TH = Hot water outlet temperature (°C)

TC = Chilled water outlet temperature (°C)

Hot water outlet temperature is 5°C higher than inlet temperature

Chilled water outlet temperature is 5°C lower than inlet temperature

UNIT	TH→	40.0				45.0				50.0				55.0				60.0			
	TC	Q	P	COP	Q	P	COP	Q	P	COP	Q	P	COP	Q	P	COP	Q	P	COP		
ED20MT	-5.0	10.8	3.2	3.3	10.2	3.3	3.1	9.6	3.3	2.9	8.9	3.4	2.7	8.3	3.4	2.5					
	0.0	13.2	3.6	3.7	12.6	3.7	3.4	11.9	3.8	3.1	11.2	3.9	2.9	10.5	3.9	2.7					
	5.0	15.8	3.9	4.0	15.1	4.1	3.7	14.4	4.2	3.4	13.7	4.4	3.1	12.9	4.5	2.9					
	10.0	18.7	4.2	4.4	18.0	4.5	4.0	17.2	4.6	3.7	16.4	4.8	3.4	15.6	5.0	3.1					
	15.0	21.9	4.6	4.8	21.1	4.8	4.4	20.3	5.0	4.0	19.4	5.3	3.7	18.5	5.5	3.4					
	20.0	25.4	4.9	5.2	24.5	5.1	4.8	23.6	5.4	4.3	22.6	5.7	4.0	21.7	6.0	3.6					
ED30MT	-5.0	16.6	5.0	3.3	15.5	5.1	3.1	14.4	5.1	2.8	13.2	5.1	2.6	12.1	5.1	2.4					
	0.0	20.4	5.6	3.6	19.3	5.7	3.4	18.2	5.9	3.1	17.0	5.9	2.9	15.7	6.0	2.6					
	5.0	24.7	6.2	4.0	23.5	6.4	3.7	22.3	6.6	3.4	21.0	6.7	3.1	19.6	6.9	2.9					
	10.0	29.6	6.7	4.4	28.1	7.0	4.0	26.8	7.3	3.7	25.4	7.5	3.4	23.8	7.7	3.1					
	15.0	34.8	7.3	4.8	33.3	7.6	4.4	31.7	7.9	4.0	30.1	8.2	3.7	28.5	8.5	3.3					
	20.0	40.7	7.9	5.2	39.0	8.3	4.7	37.2	8.6	4.3	35.3	9.0	3.9	33.5	9.4	3.6					
ED40MT	-5.0	22.4	6.6	3.4	21.2	6.7	3.2	20.0	6.8	2.9	18.7	6.9	2.7	17.4	6.9	2.5					
	0.0	27.1	7.3	3.7	25.9	7.5	3.5	24.6	7.7	3.2	23.2	7.8	3.0	21.8	7.9	2.8					
	5.0	32.3	7.9	4.1	31.0	8.2	3.8	29.6	8.5	3.5	28.2	8.7	3.2	26.7	8.9	3.0					
	10.0	38.1	8.6	4.4	36.6	8.9	4.1	35.1	9.3	3.8	33.6	9.6	3.5	31.9	9.9	3.2					
	15.0	44.5	9.3	4.8	42.9	9.7	4.4	41.2	10.1	4.1	39.5	10.5	3.8	37.6	10.8	3.5					
	20.0	51.6	10.0	5.2	49.7	10.4	4.8	47.8	10.9	4.4	45.9	11.4	4.0	43.9	11.8	3.7					
ED50MT	-5.0	28.3	8.6	3.3	27.0	8.8	3.1	25.5	8.9	2.9	24.0	9.0	2.7	22.4	9.0	2.5					
	0.0	34.2	9.5	3.6	32.7	9.8	3.3	31.2	10.1	3.1	29.5	10.2	2.9	27.8	10.4	2.7					
	5.0	40.8	10.4	3.9	39.1	10.8	3.6	37.4	11.2	3.3	35.6	11.4	3.1	33.7	11.7	2.9					
	10.0	48.0	11.3	4.2	46.2	11.8	3.9	44.3	12.2	3.6	42.3	12.6	3.4	40.2	13.0	3.1					
	15.0	56.1	12.3	4.6	53.9	12.8	4.2	51.8	13.3	3.9	49.6	13.8	3.6	47.3	14.2	3.3					
	20.0	65.0	13.3	4.9	62.7	13.8	4.5	60.2	14.4	4.2	57.7	15.0	3.8	55.0	15.5	3.6					
ED60MT	-5.0	33.1	10.0	3.3	31.1	10.2	3.1	28.8	10.2	2.8	26.5	10.2	2.6	24.2	10.1	2.4					
	0.0	40.8	11.2	3.6	38.6	11.5	3.4	36.4	11.7	3.1	33.9	11.9	2.9	31.3	11.9	2.6					
	5.0	49.4	12.3	4.0	47.0	12.8	3.7	44.5	13.1	3.4	41.9	13.5	3.1	39.2	13.7	2.9					
	10.0	59.1	13.4	4.4	56.3	14.0	4.0	53.6	14.5	3.7	50.7	15.0	3.4	47.7	15.4	3.1					
	15.0	69.6	14.6	4.8	66.7	15.3	4.4	63.4	15.9	4.0	60.2	16.5	3.7	56.9	17.1	3.3					
	20.0	81.4	15.8	5.2	77.9	16.5	4.7	74.4	17.3	4.3	70.7	18.0	3.9	67.0	18.7	3.6					
ED80MT	-5.0	44.7	13.1	3.4	42.5	13.4	3.2	40.0	13.6	2.9	37.4	13.7	2.7	34.7	13.7	2.5					
	0.0	54.1	14.5	3.7	51.7	15.0	3.5	49.2	15.4	3.2	46.5	15.6	3.0	43.6	15.8	2.8					
	5.0	64.6	15.9	4.1	62.1	16.5	3.8	59.3	17.0	3.5	56.4	17.4	3.2	53.3	17.8	3.0					
	10.0	76.3	17.2	4.4	73.3	17.9	4.1	70.3	18.6	3.8	67.2	19.2	3.5	63.9	19.8	3.2					
	15.0	89.1	18.5	4.8	85.8	19.3	4.4	82.4	20.1	4.1	78.9	20.9	3.8	75.2	21.6	3.5					
	20.0	103.2	19.9	5.2	99.4	20.8	4.8	95.6	21.8	4.4	91.8	22.7	4.0	87.7	23.6	3.7					
ED100MT	-5.0	56.6	17.2	3.3	53.9	17.6	3.1	51.0	17.9	2.9	48.0	18.0	2.7	44.9	18.1	2.5					
	0.0	68.3	19.0	3.6	65.5	19.6	3.3	62.4	20.1	3.1	59.1	20.5	2.9	55.6	20.7	2.7					
	5.0	81.5	20.9	3.9	78.1	21.6	3.6	74.8	22.3	3.3	71.3	22.9	3.1	67.5	23.4	2.9					
	10.0	96.1	22.6	4.2	92.5	23.6	3.9	88.6	24.4	3.6	84.5	25.2	3.4	80.4	25.9	3.1					
	15.0	112.1	24.5	4.6	107.9	25.5	4.2	103.7	26.6	3.9	99.2	27.5	3.6	94.6	28.4	3.3					
	20.0	130.1	26.5	4.9	125.3	27.7	4.5	120.4	28.8	4.2	115.4	30.0	3.8	109.9	31.0	3.6					

ED-MT Series: Water heating and cooling mode

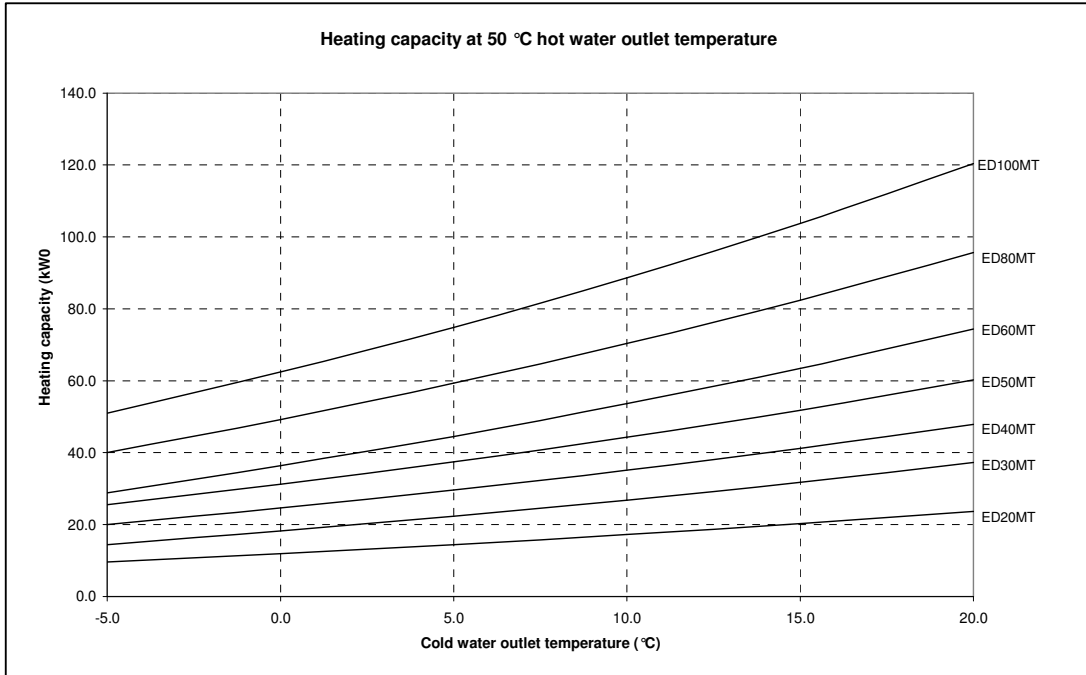

ED-MT Series: Water heating and cooling mode

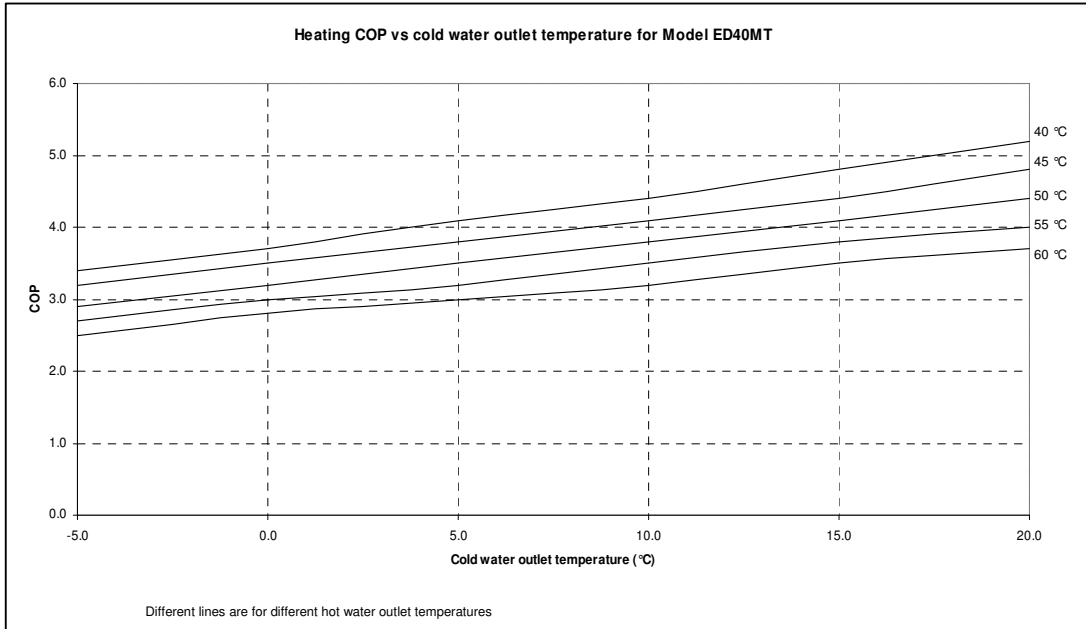

COOLING CAPACITY: WATER HEATING AND WATER COOLING MODE

Q = Cooling capacity (kW)

P = Power input, including fan, excluding pump (kW)

COP = Coefficient of performance (Q/P)

TH = Hot water outlet temperature (°C)

TC = Chilled water outlet temperature (°C)

Hot water outlet temperature is 5°C higher than inlet temperature,

Chilled water outlet temperature is 5°C lower than inlet temperature

UNIT	TH→	40.0				45.0				50.0				55.0				60.0			
	TC	Q	P	COP	Q	P	COP	Q	P	COP	Q	P	COP	Q	P	COP	Q	P	COP		
ED20MT	-5.0	7.6	3.2	2.3	6.9	3.3	2.1	6.2	3.3	1.9	5.6	3.4	1.7	4.9	3.4	1.5					
	0.0	9.6	3.6	2.7	8.8	3.7	2.4	8.1	3.8	2.1	7.3	3.9	1.9	6.6	3.9	1.7					
	5.0	11.9	3.9	3.0	11.0	4.1	2.7	10.2	4.2	2.4	9.3	4.4	2.1	8.5	4.5	1.9					
	10.0	14.5	4.2	3.4	13.5	4.5	3.0	12.6	4.6	2.7	11.6	4.8	2.4	10.6	5.0	2.1					
	15.0	17.3	4.6	3.8	16.3	4.8	3.4	15.2	5.0	3.0	14.1	5.3	2.7	13.0	5.5	2.4					
	20.0	20.5	4.9	4.2	19.3	5.1	3.8	18.1	5.4	3.3	16.9	5.7	3.0	15.7	6.0	2.6					
ED30MT	-5.0	11.6	5.0	2.3	10.4	5.1	2.1	9.3	5.1	1.8	8.1	5.1	1.6	7.0	5.1	1.4					
	0.0	14.8	5.6	2.6	13.6	5.7	2.4	12.3	5.9	2.1	11.0	5.9	1.9	9.7	6.0	1.6					
	5.0	18.6	6.2	3.0	17.1	6.4	2.7	15.7	6.6	2.4	14.2	6.7	2.1	12.7	6.9	1.9					
	10.0	22.8	6.7	3.4	21.1	7.0	3.0	19.6	7.3	2.7	17.9	7.5	2.4	16.1	7.7	2.1					
	15.0	27.5	7.3	3.8	25.7	7.6	3.4	23.7	7.9	3.0	21.9	8.2	2.7	19.9	8.5	2.3					
	20.0	32.8	7.9	4.2	30.7	8.3	3.7	28.6	8.6	3.3	26.3	9.0	2.9	24.1	9.4	2.6					
ED40MT	-5.0	15.8	6.6	2.4	14.5	6.7	2.2	13.2	6.8	1.9	11.8	6.9	1.7	10.5	6.9	1.5					
	0.0	19.8	7.3	2.7	18.4	7.5	2.5	16.9	7.7	2.2	15.4	7.8	2.0	13.9	7.9	1.8					
	5.0	24.4	7.9	3.1	22.8	8.2	2.8	21.1	8.5	2.5	19.5	8.7	2.2	17.8	8.9	2.0					
	10.0	29.5	8.6	3.4	27.7	8.9	3.1	25.8	9.3	2.8	24.0	9.6	2.5	22.1	9.9	2.2					
	15.0	35.3	9.3	3.8	33.2	9.7	3.4	31.1	10.1	3.1	29.0	10.5	2.8	26.8	10.8	2.5					
	20.0	41.6	10.0	4.2	39.3	10.4	3.8	36.9	10.9	3.4	34.5	11.4	3.0	32.1	11.8	2.7					
ED50MT	-5.0	19.7	8.6	2.3	18.2	8.8	2.1	16.6	8.9	1.9	15.0	9.0	1.7	13.4	9.0	1.5					
	0.0	24.6	9.5	2.6	22.9	9.8	2.3	21.1	10.1	2.1	19.3	10.2	1.9	17.4	10.4	1.7					
	5.0	30.3	10.4	2.9	28.3	10.8	2.6	26.2	11.2	2.3	24.2	11.4	2.1	22.1	11.7	1.9					
	10.0	36.7	11.3	3.2	34.5	11.8	2.9	32.1	12.2	2.6	29.7	12.6	2.4	27.3	13.0	2.1					
	15.0	43.8	12.3	3.6	41.2	12.8	3.2	38.5	13.3	2.9	35.8	13.8	2.6	33.1	14.2	2.3					
	20.0	51.8	13.3	3.9	48.8	13.8	3.5	45.8	14.4	3.2	42.7	15.0	2.8	39.5	15.5	2.6					
ED60MT	-5.0	23.1	10.0	2.3	20.9	10.2	2.1	18.6	10.2	1.8	16.3	10.2	1.6	14.1	10.1	1.4					
	0.0	29.6	11.2	2.6	27.2	11.5	2.4	24.6	11.7	2.1	22.1	11.9	1.9	19.4	11.9	1.6					
	5.0	37.1	12.3	3.0	34.2	12.8	2.7	31.4	13.1	2.4	28.5	13.5	2.1	25.5	13.7	1.9					
	10.0	45.7	13.4	3.4	42.3	14.0	3.0	39.1	14.5	2.7	35.7	15.0	2.4	32.3	15.4	2.1					
	15.0	55.0	14.6	3.8	51.4	15.3	3.4	47.5	15.9	3.0	43.7	16.5	2.7	39.9	17.1	2.3					
	20.0	65.6	15.8	4.2	61.4	16.5	3.7	57.1	17.3	3.3	52.7	18.0	2.9	48.2	18.7	2.6					
ED80MT	-5.0	31.6	13.1	2.4	29.0	13.4	2.2	26.3	13.6	1.9	23.6	13.7	1.7	21.0	13.7	1.5					
	0.0	39.6	14.5	2.7	36.8	15.0	2.5	33.9	15.4	2.2	30.9	15.6	2.0	27.8	15.8	1.8					
	5.0	48.7	15.9	3.1	45.6	16.5	2.8	42.3	17.0	2.5	38.9	17.4	2.2	35.5	17.8	2.0					
	10.0	59.1	17.2	3.4	55.4	17.9	3.1	51.7	18.6	2.8	48.0	19.2	2.5	44.1	19.8	2.2					
	15.0	70.6	18.5	3.8	66.5	19.3	3.4	62.3	20.1	3.1	58.0	20.9	2.8	53.6	21.6	2.5					
	20.0	83.3	19.9	4.2	78.6	20.8	3.8	73.8	21.8	3.4	69.1	22.7	3.0	64.1	23.6	2.7					
ED100MT	-5.0	39.4	17.2	2.3	36.3	17.6	2.1	33.1	17.9	1.9	29.9	18.0	1.7	26.8	18.1	1.5					
	0.0	49.3	19.0	2.6	45.8	19.6	2.3	42.3	20.1	2.1	38.6	20.5	1.9	34.8	20.7	1.7					
	5.0	60.6	20.9	2.9	56.5	21.6	2.6	52.5	22.3	2.3	48.4	22.9	2.1	44.1	23.4	1.9					
	10.0	73.5	22.6	3.2	68.9	23.6	2.9	64.2	24.4	2.6	59.4	25.2	2.4	54.5	25.9	2.1					
	15.0	87.6	24.5	3.6	82.4	25.5	3.2	77.1	26.6	2.9	71.7	27.5	2.6	66.2	28.4	2.3					
	20.0	103.6	26.5	3.9	97.6	27.7	3.5	91.6	28.8	3.2	85.4	30.0	2.8	79.0	31.0	2.6					

ED-MT Series: Water heating and cooling mode

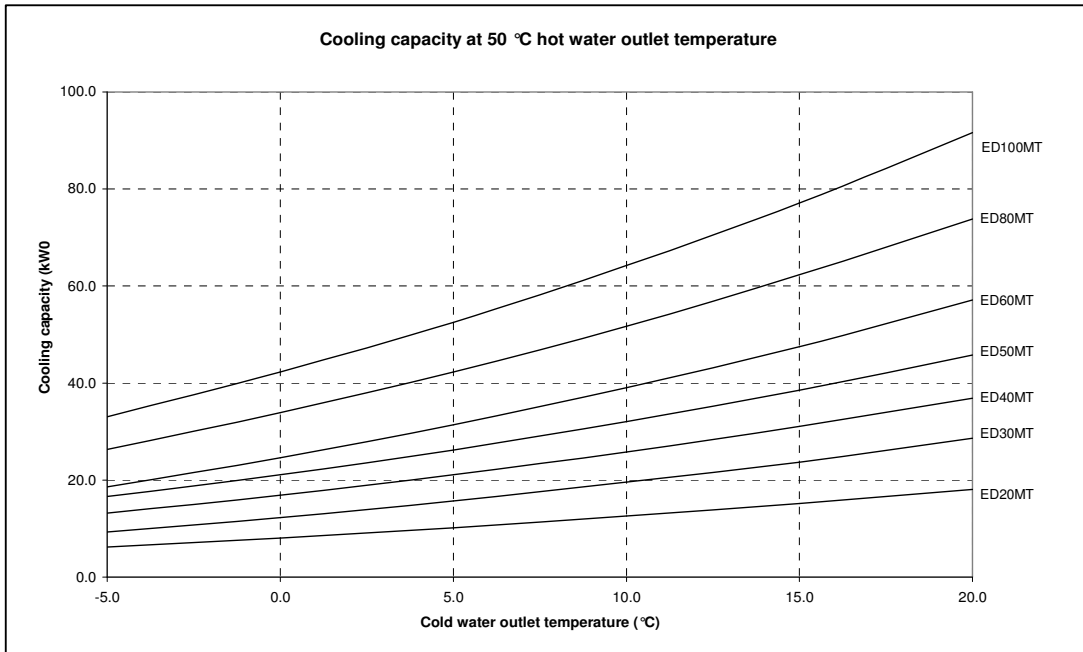

ED Series: Water heating and cooling mode

