

TECHNICAL BROCHURE



AIR COOLED WATER CHILLERS

6kW – 100kW

MANUFACTURED BY:



M - T e c h
industrial

CONTACT DETAILS:

+27 18 297 0326 / 7 (Tel)

+27 18 297 0318 (Fax)

www.mtechindustrial.com

PHYSICAL ADDRESS:

24 Totius street

Totius park Block E

Potchefstroom

2531

POSTAL ADDRESS:

PO Box 19855

Noordbrug

2522

ENERFLOW EC-MT: AIR COOLED PACKAGED WATER CHILLERS

ENERFLOW EC-MT series water chillers are compact and highly energy efficient. The units are completely self-contained, easy to install and easy to maintain.

The **ENERFLOW** EC-MT series chiller units can also be used to cool other fluids like glycol, to produce ice.

APPLICATIONS

ENERFLOW EC-MT series water chillers are ideally suited for the following applications:

- Air-conditioning.
- Cooling of injection moulding or other production machines.
- Production of ice.
- Cold storage.
- Industrial cooling.

MODELS

ENERFLOW EC-MT series chillers are available in 11 sizes ranging from 6 kW to 100 kW in cooling capacity.

EASY INSTALLATION

Installation is a simple matter of water pipe connections and power supply. The units are designed for outdoor as well as indoor applications. The only requirement is access to external air. The units are particularly compact and light, ensuring easy transportation and installation.

SPACE SAVING

No machine room is required for installation. The units can be installed on the roof top, on the ground or anywhere outdoors. Air enters the units on three sides while it is discharged at the top.

NO MAINTENANCE

The units are assembled, internally wired and charged with refrigerant at the factory and is subject to stringent test operation before delivery. The units are sealed and designed for trouble free operation.

QUIET OPERATION

Advanced fans with airfoil blades and a very low noise level are used on the superheat EC series water chillers. The fan motors are also protected against moisture and dust.

TECHNOLOGY

ENERFLOW EC series water chillers are the end product of a fine engineering effort piloted by M-Tech Industrial in collaboration with other engineering research institutes. Computer aided design verified by experimental testing supported the project throughout its development and manufacturing phases.

OPERATING LIMITS

Ambient temperatures not exceeding 42 °C. Inlet water temperatures not exceeding 25 °C. Water outlet temperatures not lower than 6 °C. Glycol outlet temperatures not lower than -10 °C.

WARRANTY

M-Tech Industrial warrants this equipment to be free from defects in material and workmanship for a period of 12 months from date of shipment provided the correct installation and water treatment procedures were followed. Any units or parts proving defective within this period will be repaired or replaced at our option when returned to our factory, transportation charges pre-paid. M-Tech Industrial will not be responsible for any installation or removal costs.

PRINCIPLES OF OPERATION

ENERFLOW EC-MT heat pumps are based on the well known vapour-compression refrigeration cycle, described and illustrated below:

- The refrigerant enters the compressor as vapour at low pressure and temperature.
- It enters the water heat exchanger as vapour at a high pressure and temperature.
- The refrigerant is condensed as a result of the heat that is transferred to the air.
- The pressure of the liquid decreases through the expansion valve causing the temperature to drop sharply.
- The liquid at low pressure vaporizes in the water heat exchanger as a result of heat transfer from the water.

- The cycle is completed as vapour re-enters the compressor.

EC REFRIGERATION CYCLE

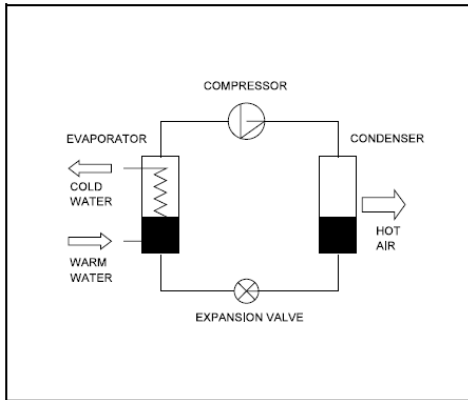

MAJOR DIMENTIONS
Models -6 and -8

MODEL	-6	-8
W (mm)	1030	1030
H (mm)	677	677
D (mm)	600	600

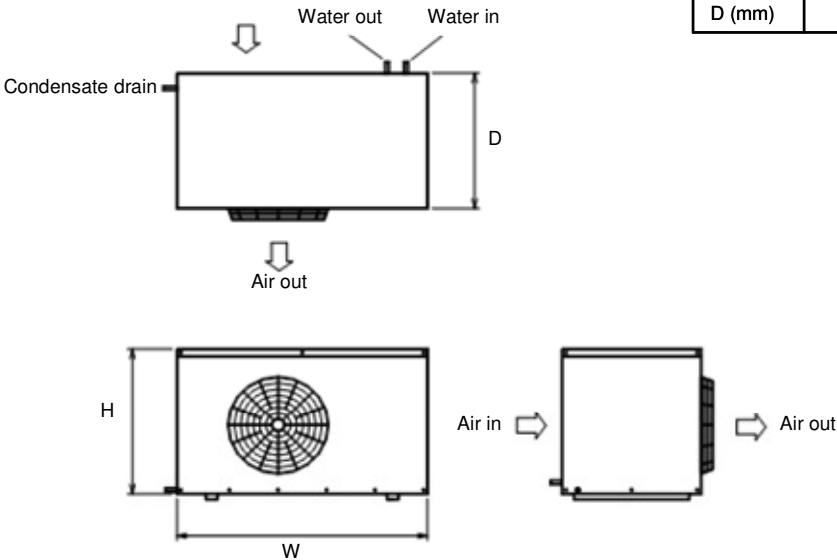

MAJOR DIMENTIONS
Models -12, -16 and -20

MODEL	-12	-16	-20
W (mm)	1300	1300	1400
H (mm)	776	776	1030
D (mm)	776	720	740

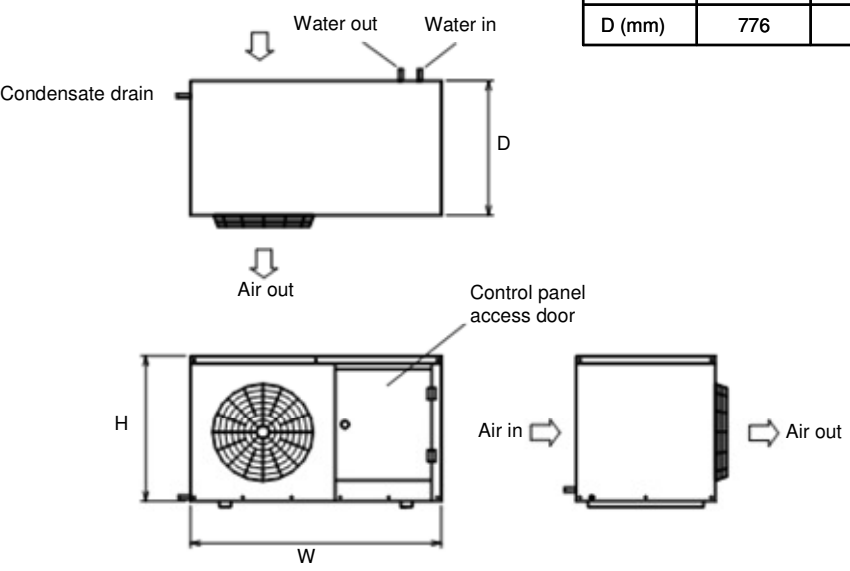

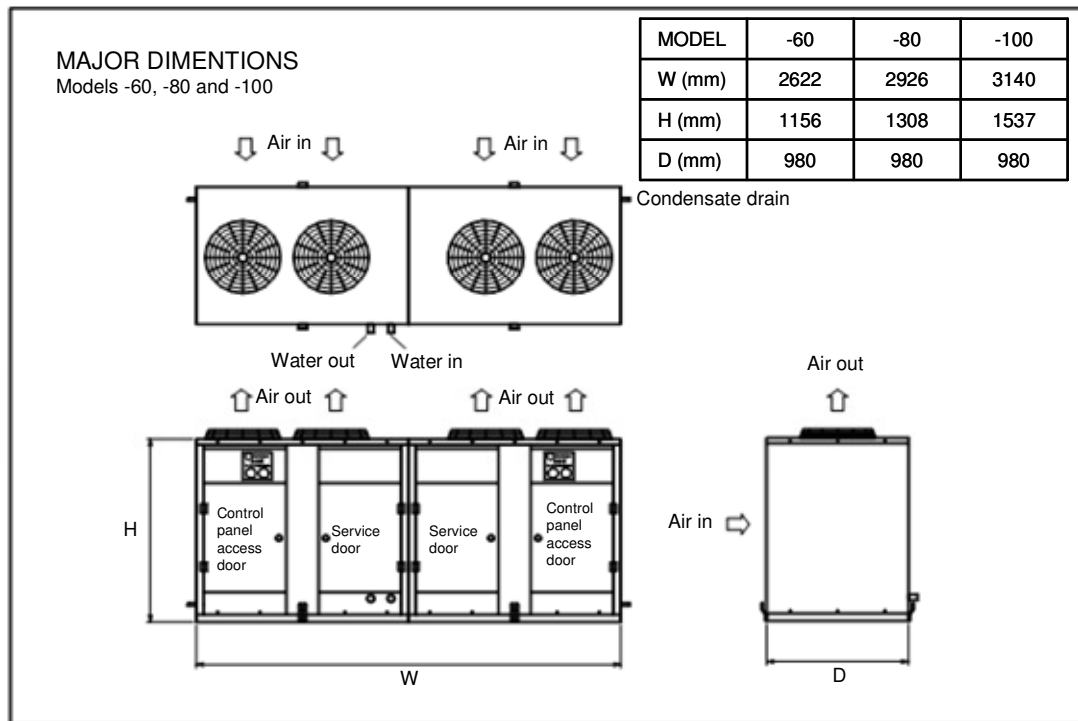
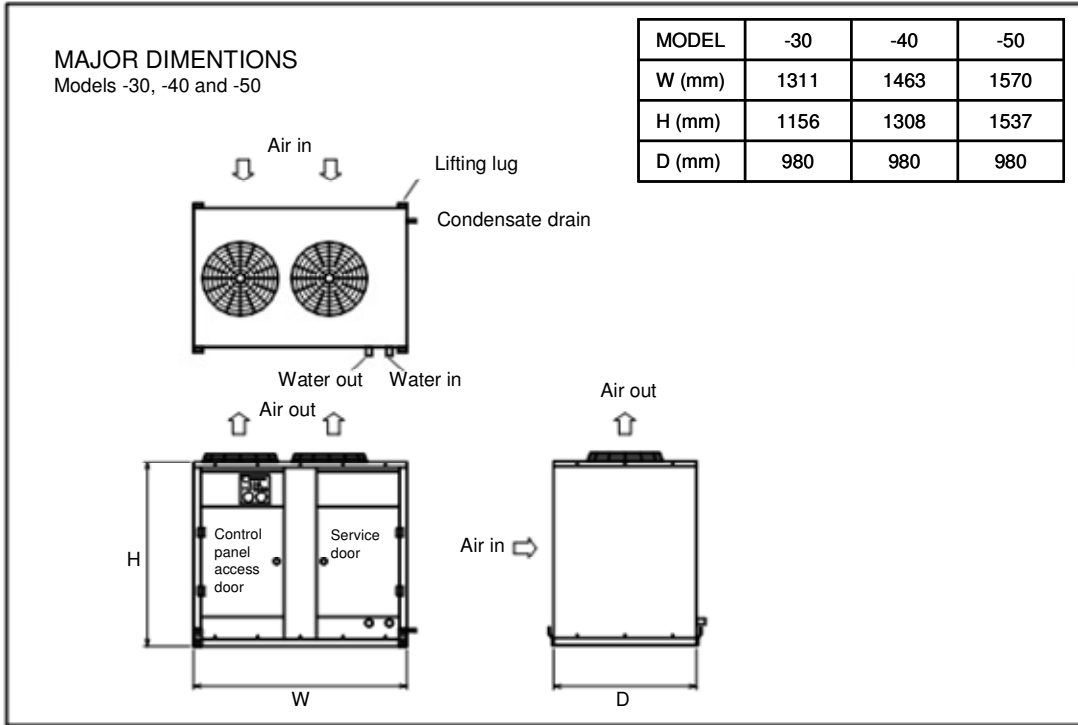

SPECIFICATIONS: ENERFLOW EC PACKAGED WATER CHILLERS

MODEL		EC6MT	EC8MT	EC12MT	EC16MT	EC20MT
RATING		(15°C in, 10°C out, air 30°C DB)				
Cooling capacity	kW	4.3	5.4	7.5	10.9	14.4
Water flow	l/min	12.3	15.5	21.5	31.3	41.3
COP		3.0	3.0	3.0	3.0	3.1
ELECTRICAL (50 Hz)						
Phases		1	1	1	3	3
Voltage Volt	240	240	240	380	380	
Power (Max cont.)	kW	1.9	2.4	3.5	5	6.4
Current (Max cont.)	Amps	8.6	10.3	16.7	10.3	10.9
CAPACITY STEPS		100 – 0	100 – 0	100 – 0	100 – 0	100 – 0
CASING		Stainless Steel				
Dimension H x W x D	mm	677x1030 x600	677x1030 x600	776x1300 x720	776x1300 x720	1030x1400 x740
COMPRESSOR		Rotary		Hermetically sealed reciprocating		
No. of cylinders			2	2	4	4
Displacement 50 Hz	m ³ /h	5.7	7	10	13.6	17.7
Speed	rpm	2900	2900	2900	2900	2900
Oil charge	Fl oz	24	36	55	70	70
Oil type		Caltex Capella WF32				
HEAT EXCHANGER (WATER)		Fluted tube				
HEAT EXCHANGER (AIR)						
(Rows x Columns) x No.		3 x 24 x 1	3 x 24 x 1	3 x 28 x 1	4 x 28 x 1	4 x 36 x 1
Number of circuits		3	3	4	6	8
Fin patch	mm	2.5	2.5	2.5	2.5	2.5
Face area	m ²	0.28	0.35	0.51	0.51	0.66
FAN		Axial flow				
Fan speed	rpm	1250	1250	900	1100	1350
Fan diameter	mm	350	350	500	500	500
Air flow	m ³ /min	40	44	79	80	122
Face velocity	m/s	2.4	2.1	2.6	2.6	3.1
Power input	kW	0.2	0.2	0.32	0.5	0.7
Noise level	dB 3m	56	56	73	79	83
REFRIGERANT		R22				
Control		Thermostatic expansion valve				
No. of circuits		1	1	1	1	1
Charge	kg	2	3	4	5	6
PIPE CONNECTION						
Water inlet/outlet	mm	19.1	19.1	19.1	25.4	25.4
Drain	mm	12.7	12.7	12.7	19.1	19.1
MACHINE WEIGHT	kg	120	150	200	250	300

SPECIFICATIONS: ENERFLOW EC PACKAGED WATER CHILLERS

MODEL		EC30MT	EC40MT	EC50MT	EC60MT	EC80MT	EC100MT
RATING		(15°C in, 10°C out, air 30°C DB)					
Cooling capacity	kW	22.3	29.1	36.5	44.7	58.3	73.0
Water flow	l/min	64.0	83.5	104.8	128.3	167.4	209.6
COP		3.0	3.1	2.9	3.0	3.1	2.9
ELECTRICAL							
Phases		3	3	3	3	3	3
Voltage	Volt	380	380	380	380	380	380
Power (Max cont.)	kW	9.9	12.5	16.4	19.8	25	32.8
Current (Max cont.)	Amps	20	24.2	35	40	48.4	70
CAPACITY STEPS		100 – 0	100 – 0	100 – 0	100 – 50 – 0	100 – 50 – 0	100 – 50 – 0
CASING		Stainless Steel					
Dimension H x W x D	mm	1156 x 1311 x 980	1308 x 1463 x 980	1537 x 1570 x 980	1156 x 2622 x 980	1308 x 2926 x 980	1537 x 3140 x 980
COMPRESSOR		Hermetically sealed reciprocating					
No. of cylinders		4	4	4	4x2	4x2	4x2
Displacement 50 Hz	m ³ /h	30.9	38.6	46.3	30.9 x 2	38.6 x 2	46.3 x 2
Speed	rpm	2900	2900	2900	2900	2900	2900
Oil charge	Fl oz	128	128	128	128 x 2	128 x 2	128 x 2
Oil type		Caltex Capella WF32					
HEAT EXCHANGER (WATER)		Fluted tube					
HEAT EXCHANGER (AIR)							
(Rows x Columns) x No.		4 x 39 x 1	4 x 45 x 1	4 x 54 x 1	4 x 39 x 2	4 x 45 x 2	4 x 54 x 2
Number of circuits		13	15	18	13 x 2	15 x 2	18 x 2
Fin pitch	mm	2.5	2.5	2.5	2.5	2.5	2.5
Face area	m ²	0.98	1.31	1.72	0.98 x 2	1.31 x 2	1.72 x 2
FAN		Axial flow					
Fan speed	rpm	1100	1350	1350	1100	1350	1350
Fan diameter	mm	500 x 2	500 x 2	500 x 2	500 x 4	500 x 4	500 x 4
Air flow	m ³ /min	156	241	267	312	482	534
Face velocity	m/s	2.7	3.1	2.6	2.7	3.1	2.6
Power input	kW	0.5 x 2	0.7 x 2	0.7 x 2	0.5 x 4	0.7 x 4	0.7 x 4
Noise level	dB 3m	79	83	83	79	83	83
REFRIGERANT		R22					
Control		Thermostatic expansion valve					
No. of circuits		1	1	1	2	2	2
Charge	kg	7	8	9	7 x 2	8 x 2	9 x 2
PIPE CONNECTION							
Water in let/outlet	mm	31.8	38.1	38.1	38.1	50.8	50.8
Drain	mm	19.1	19.1	19.1	19.1	19.1	19.1
MACHINE WEIGHT		kg	350	400	450	700	800

COOLING CAPACITY (EC6MT - EC20MT)

Q = Cooling capacity (kW)

P = Power input, including fan, excluding pump (kW)

COP = Coefficient of performance (Q/P)

T_{wat} = Chilled water outlet temperature (°C)

T_{amb} = Ambient air dry-bulb temperature (°C)

Chilled water outlet temperature is 5°C lower than inlet temperature

UNIT	T _{amb} →	20			25			30			35			40		
	T _{wat}	Q	P	COP	Q	P	COP	Q	P	COP	Q	P	COP	Q	P	COP
EC6MT	-5.0	2.6	1.1	2.5	2.5	1.1	2.2	2.3	1.2	1.9	2.1	1.2	1.7	1.9	1.3	1.5
	0.0	3.3	1.2	2.8	3.1	1.2	2.5	2.9	1.3	2.3	2.7	1.3	2.0	2.5	1.4	1.8
	5.0	4.0	1.2	3.3	3.8	1.3	2.9	3.6	1.4	2.6	3.3	1.4	2.3	3.1	1.5	2.1
	10.0	4.9	1.3	3.7	4.6	1.4	3.3	4.3	1.5	3.0	4.0	1.5	2.6	3.8	1.6	2.4
	15.0	5.7	1.4	4.1	5.4	1.5	3.7	5.1	1.6	3.3	4.8	1.6	2.9	4.5	1.7	2.6
	20.0	6.7	1.5	4.5	6.4	1.6	4.0	6.0	1.7	3.6	5.7	1.7	3.2	5.3	1.8	2.9
EC8MT	-5.0	3.3	1.3	2.4	3.1	1.4	2.2	2.8	1.5	1.9	2.6	1.5	1.7	2.4	1.6	1.5
	0.0	4.1	1.4	2.8	3.8	1.5	2.5	3.6	1.6	2.2	3.4	1.7	2.0	3.1	1.7	1.8
	5.0	5.0	1.5	3.2	4.7	1.6	2.9	4.4	1.7	2.6	4.2	1.8	2.3	3.9	1.9	2.1
	10.0	6.0	1.6	3.7	5.7	1.7	3.3	5.4	1.8	3.0	5.1	1.9	2.7	4.8	2.0	2.4
	15.0	7.2	1.8	4.1	6.8	1.9	3.7	6.4	2.0	3.3	6.1	2.0	3.0	5.7	2.1	2.7
	20.0	8.4	1.9	4.5	8.0	2.0	4.0	7.6	2.1	3.6	7.2	2.2	3.3	6.7	2.3	3.0
EC12MT	-5.0	4.5	1.9	2.4	4.2	1.9	2.2	3.9	2.0	1.9	3.7	2.1	1.7	3.4	2.2	1.5
	0.0	5.6	2.0	2.8	5.3	2.1	2.5	4.9	2.2	2.3	4.6	2.3	2.0	4.3	2.4	1.8
	5.0	6.9	2.1	3.3	6.5	2.2	2.9	6.1	2.3	2.6	5.8	2.4	2.4	5.4	2.6	2.1
	10.0	8.3	2.2	3.8	7.9	2.4	3.3	7.5	2.5	3.0	7.0	2.6	2.7	6.6	2.8	2.4
	15.0	9.9	2.4	4.2	9.4	2.5	3.7	8.9	2.7	3.3	8.5	2.8	3.0	8.0	3.0	2.7
	20.0	11.6	2.5	4.6	11.1	2.7	4.1	10.6	2.9	3.7	10.0	3.0	3.3	9.5	3.2	3.0
EC16MT	-5.0	7.0	2.5	2.8	6.5	2.6	2.5	5.9	2.7	2.2	5.4	2.8	1.9	4.9	2.8	1.7
	0.0	8.6	2.8	3.1	8.0	2.9	2.8	7.4	3.0	2.5	6.8	3.1	2.2	6.2	3.2	2.0
	5.0	10.4	3.0	3.5	9.7	3.2	3.1	9.1	3.3	2.7	8.4	3.4	2.5	7.8	3.5	2.2
	10.0	12.3	3.3	3.8	11.6	3.4	3.4	10.9	3.6	3.0	10.2	3.8	2.7	9.4	3.9	2.4
	15.0	14.4	3.5	4.1	13.6	3.7	3.7	12.8	3.9	3.3	12.0	4.1	2.9	11.2	4.3	2.6
	20.0	16.8	3.8	4.4	15.9	4.0	3.9	15.0	4.3	3.5	14.1	4.5	3.1	13.1	4.7	2.8
EC20MT	-5.0	9.3	3.3	2.8	8.6	3.5	2.5	8.0	3.6	2.2	7.4	3.7	2.0	6.7	3.7	1.8
	0.0	11.3	3.7	3.1	10.6	3.8	2.8	9.9	3.9	2.5	9.2	4.1	2.3	8.5	4.2	2.0
	5.0	13.6	3.9	3.4	12.8	4.1	3.1	12.0	4.3	2.8	11.2	4.5	2.5	10.4	4.6	2.3
	10.0	16.2	4.3	3.8	15.3	4.5	3.4	14.4	4.7	3.1	13.5	4.9	2.8	12.6	5.1	2.5
	15.0	18.9	4.6	4.1	17.9	4.9	3.7	17.0	5.1	3.3	16.0	5.3	3.0	15.0	5.5	2.7
	20.0	21.9	5.0	4.4	20.8	5.3	4.0	19.7	5.5	3.6	18.6	5.8	3.2	17.5	6.0	2.9

COOLING CAPACITY (EC30MT - EC 100MT)

Q = Cooling capacity (kW)

P = Power input, including fan, excluding pump (kW)

COP = Coefficient of performance (Q/P)

T_{wat} = Chilled water outlet temperature (°C)

T_{amb} = Ambient air dry-bulb temperature (°C)

Chilled water outlet temperature is 5°C lower than inlet temperature

UNIT	T _{amb} →	20			25			30			35			40		
	T _{wat}	Q	P	COP	Q	P	COP	Q	P	COP	Q	P	COP	Q	P	COP
EC30MT	-5.0	14.2	5.1	2.8	13.2	5.3	2.5	12.2	5.4	2.2	11.1	5.6	2.0	10.1	5.6	1.8
	0.0	17.5	5.7	3.1	16.3	5.9	2.8	15.2	6.1	2.5	14.0	6.2	2.3	12.9	6.3	2.0
	5.0	21.3	6.3	3.4	19.9	6.5	3.1	18.6	6.7	2.8	17.3	6.9	2.5	15.9	7.1	2.3
	10.0	25.4	6.9	3.7	23.9	7.1	3.3	22.3	7.4	3.0	20.8	7.6	2.7	19.4	7.9	2.5
	15.0	29.7	7.6	3.9	28.1	7.8	3.6	26.4	8.1	3.2	24.6	8.4	2.9	22.9	8.7	2.6
	20.0	34.5	8.3	4.2	32.6	8.6	3.8	30.7	8.9	3.4	28.7	9.3	3.1	26.8	9.6	2.8
EC40MT	-5.0	18.9	6.7	2.8	17.7	7.0	2.5	16.5	7.2	2.3	15.3	7.4	2.1	14.0	7.5	1.9
	0.0	22.9	7.4	3.1	21.6	7.7	2.8	20.3	7.9	2.6	18.9	8.1	2.3	17.5	8.3	2.1
	5.0	27.5	8.1	3.4	26.0	8.4	3.1	24.5	8.7	2.8	23.0	9.0	2.6	21.4	9.2	2.3
	10.0	32.6	8.8	3.7	30.9	9.2	3.4	29.1	9.5	3.1	27.4	9.8	2.8	25.7	10.1	2.5
	15.0	38.1	9.6	4.0	36.2	10.0	3.6	34.2	10.3	3.3	32.3	10.7	3.0	30.3	11.1	2.7
	20.0	43.9	10.4	4.2	41.8	10.9	3.8	39.6	11.3	3.5	37.4	11.7	3.2	35.2	12.1	2.9
EC50MT	-5.0	23.5	8.7	2.7	22.1	9.1	2.4	20.6	9.3	2.2	19.2	9.6	2.0	17.7	9.8	1.8
	0.0	28.6	9.6	3.0	27.0	10.0	2.7	25.3	10.3	2.5	23.7	10.6	2.2	22.0	10.9	2.0
	5.0	34.4	10.5	3.3	32.5	10.9	3.0	30.6	11.3	2.7	28.7	11.7	2.5	26.7	12.0	2.2
	10.0	40.7	11.5	3.5	38.6	11.9	3.2	36.5	12.4	2.9	34.3	12.8	2.7	32.1	13.2	2.4
	15.0	47.6	12.5	3.8	45.2	13.0	3.5	42.7	13.5	3.2	40.2	14.0	2.9	37.7	14.5	2.6
	20.0	55.0	13.7	4.0	52.3	14.3	3.7	49.5	14.8	3.3	46.7	15.3	3.0	43.8	15.9	2.8
EC60MT	-5.0	28.4	10.3	2.8	26.3	10.6	2.5	24.3	10.9	2.2	22.2	11.1	2.0	20.1	11.2	1.8
	0.0	35.0	11.4	3.1	32.7	11.8	2.8	30.4	12.1	2.5	28.1	12.4	2.3	25.7	12.7	2.0
	5.0	42.5	12.5	3.4	39.9	13.0	3.1	37.2	13.4	2.8	34.5	13.8	2.5	31.9	14.2	2.3
	10.0	50.8	13.7	3.7	47.8	14.3	3.3	44.7	14.8	3.0	41.7	15.3	2.7	38.7	15.7	2.5
	15.0	59.4	15.1	3.9	56.1	15.7	3.6	52.8	16.3	3.2	49.2	16.8	2.9	45.8	17.4	2.6
	20.0	69.0	16.6	4.2	65.3	17.2	3.8	61.4	17.9	3.4	57.5	18.5	3.1	53.5	19.2	2.8
EC80MT	-5.0	37.8	13.4	2.8	35.4	13.9	2.5	33.0	14.4	2.3	30.5	14.7	2.1	28.0	15.0	1.9
	0.0	45.9	14.7	3.1	43.2	15.3	2.8	40.5	15.9	2.6	37.8	16.3	2.3	35.0	16.7	2.1
	5.0	55.0	16.1	3.4	52.0	16.8	3.1	49.0	17.4	2.8	46.0	17.9	2.6	42.9	18.4	2.3
	10.0	65.2	17.6	3.7	61.8	18.3	3.4	58.3	19.0	3.1	54.8	19.6	2.8	51.3	20.2	2.5
	15.0	76.1	19.2	4.0	72.3	19.9	3.6	68.4	20.7	3.3	64.5	21.4	3.0	60.5	22.1	2.7
	20.0	87.8	20.9	4.2	83.5	21.7	3.8	79.1	22.6	3.5	74.7	23.4	3.2	70.3	24.3	2.9
EC100MT	-5.0	47.0	17.5	2.7	44.2	18.1	2.4	41.3	18.7	2.2	38.3	19.2	2.0	35.3	19.5	1.8
	0.0	57.2	19.2	3.0	54.0	20.0	2.7	50.7	20.6	2.5	47.4	21.2	2.2	44.0	21.7	2.0
	5.0	68.8	21.0	3.3	65.1	21.9	3.0	61.3	22.7	2.7	57.4	23.4	2.5	53.5	24.1	2.2
	10.0	81.5	23.0	3.5	77.3	23.9	3.2	73.0	24.8	2.9	68.6	25.6	2.7	64.1	26.4	2.4
	15.0	95.1	25.1	3.8	90.3	26.1	3.5	85.4	27.0	3.2	80.4	28	2.9	75.4	28.9	2.6
	20.0	110.0	27.4	4.0	104.5	28.5	3.7	98.9	29.6	3.3	93.3	30.6	3.0	87.6	31.7	2.8

EC-MT Series

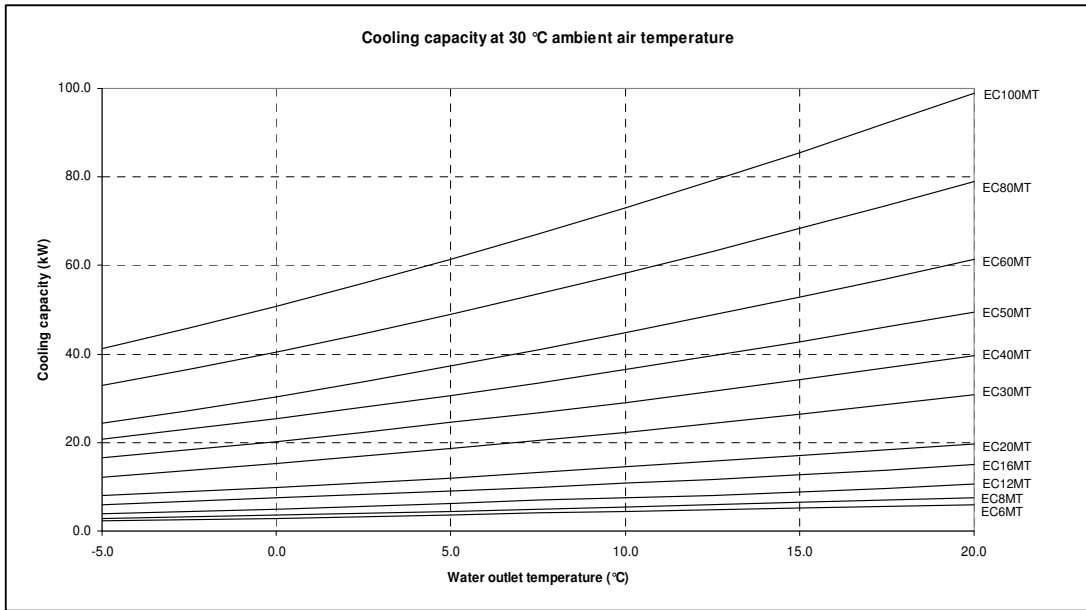

EC Series

